

1	INITIAL RELEASE	JACK WU	2015/03/11
2	NEW FORM	JACK WU	2020/04/15
3			

**SPECIFICATION:**

1. Current Rating: 0.5A
2. Insulator Resistance: 1000M Ω Min.
3. Withstanding Voltage: 500V AC
4. Contact Resistance : 100m Ω Max.
5. Durability: 10,000 Cycles Min.
6. Operating Temperature : -40°C ~ +80°C

**PIN DEFINE**

PDA No.	Memory Card
PIN-01	TF-DATA2
PIN-02	TF-CD/DATA3
PIN-03	TF-CMD
PIN-04	TF-VDD
PIN-05	TF-CLK
PIN-06	TF-VSS
PIN-07	TF-DAT0
PIN-08	TF-DAT1
PIN-09	CARD DETECT
PIN-10	GROUND

6.	SPRING	Stainless
5.	CAM PIN	Stainless
4.	SLIDER CAM	Synthetic Resin, Black
3.	CONTACT-SD	Copper Alloy, Gold Plating on Contact Area
2.	SHELL	Stainless, Gold Plating on Solder Tails
1.	HOUSING	Synthetic Resin, Black

NO.	PART NAME	DESCRIPTION															
<table border="1"> <tr> <td colspan="2">DIMENSIONS : mm</td> <td>TOLERANCES UNLESS OTHERWISE SPECIFIED :</td> </tr> <tr> <td colspan="2">X</td> <td>± 0.30</td> </tr> <tr> <td colspan="2">X.X</td> <td>± 0.20</td> </tr> <tr> <td colspan="2">X.XX</td> <td>± 0.10</td> </tr> <tr> <td colspan="2">ANGLES</td> <td>± 3°</td> </tr> </table>			DIMENSIONS : mm		TOLERANCES UNLESS OTHERWISE SPECIFIED :	X		± 0.30	X.X		± 0.20	X.XX		± 0.10	ANGLES		± 3°
DIMENSIONS : mm		TOLERANCES UNLESS OTHERWISE SPECIFIED :															
X		± 0.30															
X.X		± 0.20															
X.XX		± 0.10															
ANGLES		± 3°															
		<b>Chunxin Technology</b> NAME															
SCALE	1 : 1	DWN JACK WU 20150311															
SHEET	1/1	CHK PETER WANG 20150311															
SIZE	A4	APVD SIMON LI 20150311															
CUSTOMER DRAWING		SIMON LI															
		<b>Micro SD Socket Push Push Type</b> PRODUCT No. CX1-MSD202-21 DRAWING No. CS-MSD003															

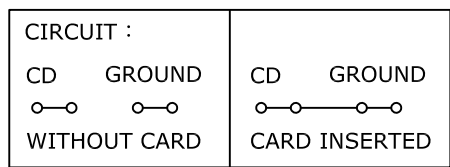
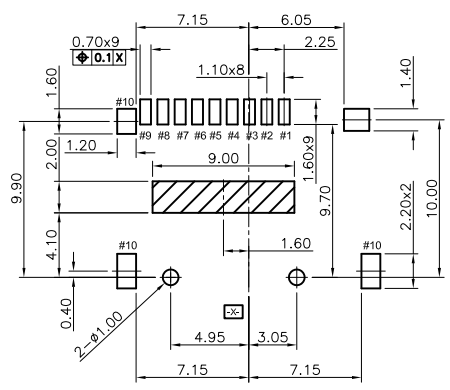
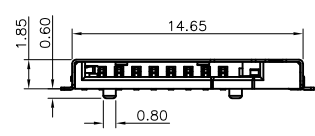
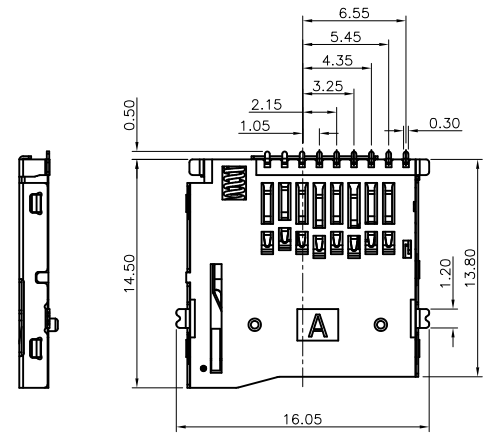
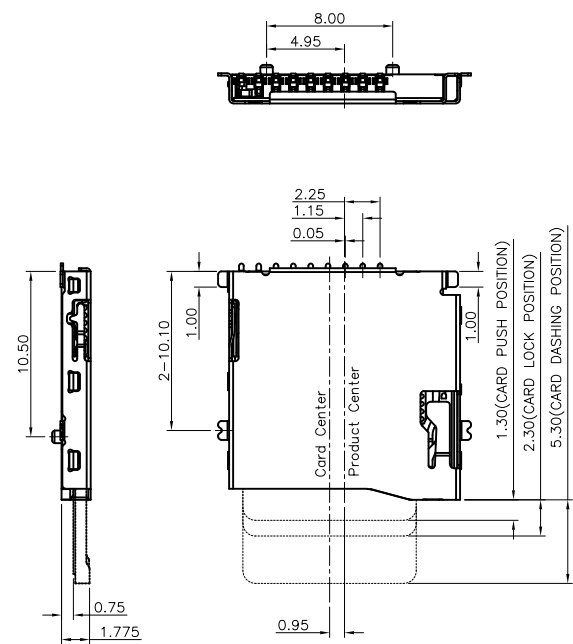
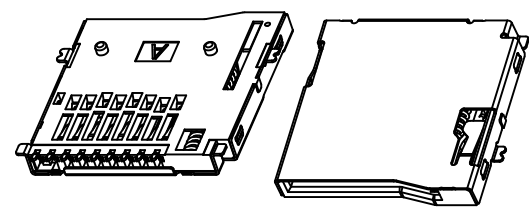

**RECOMMENDED P.C.B LAYOUT**  
**ALL TOLERANCE ±0.05mm**